

All tests in this report are executed according to the ISO 9001
 certified Quality management system of the BBRI

 Test Centre
 Offices
 Head Office

 B-1342 Limelette, avenue P. Holoffe 21
 B-1932 Sint-Stevens-Woluwe, Lozenberg 7
 B-1000 Brussels, rue du Lombard 42

 Tel.: +32 (0)2 655 77 11
 Tel.: +32 (0)2 716 42 11
 Tel.: +32 (0)2 502 66 90

TEST REPORT

Laboratory CAR	O/References	DE 651 XK 869 CAR 13305/1 Page 1/10
-----------------------	---------------------	---

Requested by	SOLUTIA EUROPE BVBA CORPORATE VILLAGE – ARAMIS BUILDING LEONARDO DA VINCILAAN 1 1935 ZAVENTEM TEL: 0470/88.44.73 - FAX:02/746.50.00		
Date of the order	2014.04.11	Samples registration	N-2014-11-023
		Date of reception of samples	2013.12.03
Date of the test	2013.12.03 to 2013.12.05		
Date of issue of the report	2014.05.09		
Test carried out	Dynamic and static tests on balustrade elements		
References	<i>NBN B03-004 : Balustrade of buildings (2010)</i> <i>prNBN B03-004: Balustrade of buildings (in preparation)</i>		

This test report contains 10 pages and 1 appendix. This test report may only be reproduced in its entirety. Each page of the original report has been stamped (in red) by the laboratory and initialled by the head of laboratory. The results and findings are only valid for the tested samples.

- No sample
- Sample(s) subjected to destructive test
- Sample(s) to be removed from our laboratories 30 calendar days after sending of the report, save in the case of a further written request



 Ing. I. Knoops
 Researcher

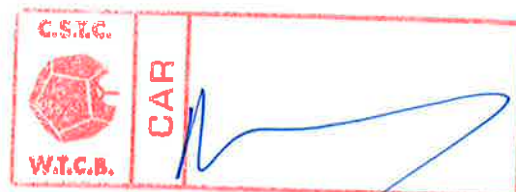

 Ir. V. Detremmerie
 Head of Laboratory

 Ir. B. Michaux
 Deputy Head of Division

1 INTRODUCTION

At request of the company Solutia Europe bvba, represented by Mr R. Speelman, the laboratory CAR of the BBRI has carried out static (horizontal loads) and dynamic tests on balustrade elements for different combinations of profiles and glass panes. The results of these tests are given in the report with reference "CAR 13305/1".

2 DESCRIPTION OF THE TEST PIECES

The test pieces were received at the research centre of the BBRI in Limelette on December 3rd 2013 and were registered in the receipts register of test pieces under the number N-2014-11-023 by the laboratory "Roof and Façade elements". It concerns glass balustrade elements for which the composition and dimensions are stated below.

2.1 SCHEMATIC REPRESENTATION OF THE TEST PIECE

The schematic representation of the test pieces is shown on *Figure 1*.

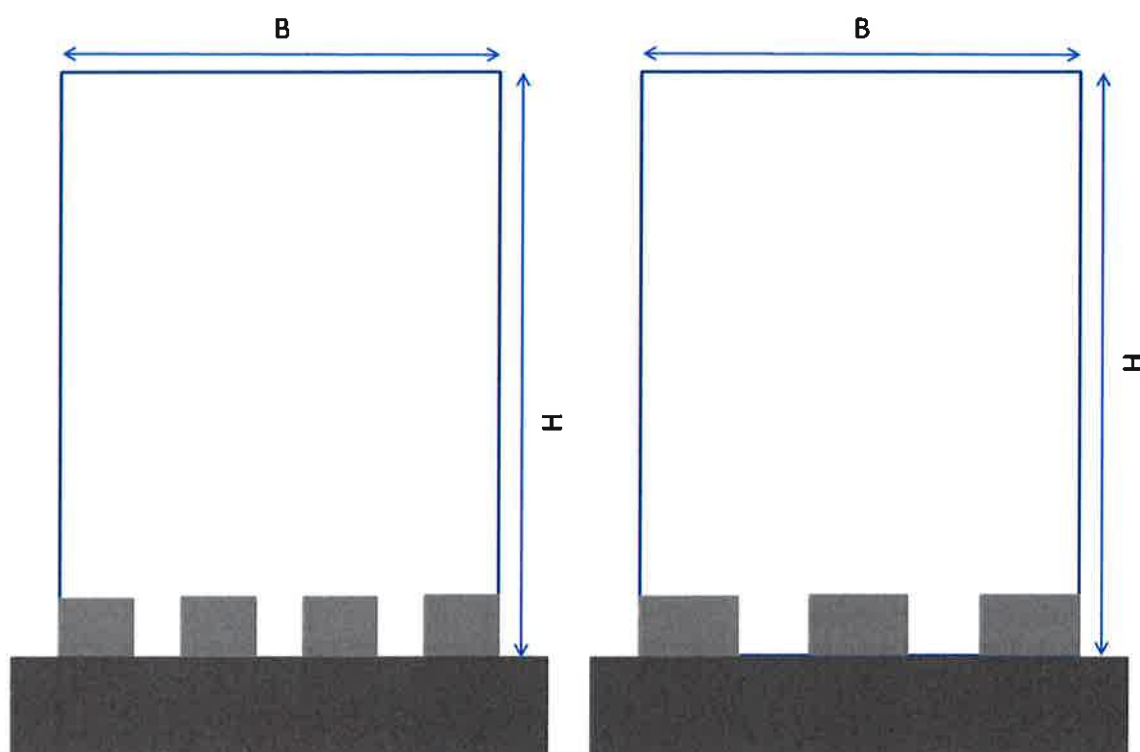

**Figure 1: Schematic representation of the test pieces: Aluminco profile, Crystal line
(Left types B and C, right type E)**



2.2 DIMENSIONS OF THE TEST PIECE

The dimensions of the test pieces and their combination with the different profiles are given in Table 1.

No.	Glass panes					Profile
	Type	Composition	Interlayer	Height (mm)	Width (mm)	
1	1010.4 mix	10 mm laminated/ 0,76 mm DG 41 / 0,76 mm RB 41/ 10 mm laminated	DG 41 + RB 41	1200	1200	Aluminco, Crystal line Type B (4 pieces)
2	88.2 DG 41	8 mm laminated/ 0,76 mm DG 41 / 8 mm laminated	DG 41	1200	1200	Aluminco, Crystal line Type B (4 pieces)
3	1010.2 DG 41	10 mm laminated/ 0,76 mm DG 41 / 10 mm laminated	DG 41	1200	1200	Aluminco, Crystal line Type E (3 pieces)
4	1010.4 mix	10 mm laminated/ 0,76 mm DG 41 / 0,76 mm RB 41/ 10 mm laminated	DG 41 + RB 41	1200	1200	Aluminco, Crystal line Type E (3 pieces)

Table 1: Dimensions of the used test pieces and profiles

An overview of the different test pieces is given in Figure 1.



Picture 1: Aluminco, Crystal line type B





Picture 2: Aluminco, Crystal line type E

2.3 DESCRIPTION OF THE TEST PIECE

The characteristics of the elements constituting the test pieces are given by the applicant and described here below:

- Glass composition: the various used glass panes are summarized in Table 1 above
- Fixation on the substrate via an Aluminium profile (top-mount). The various glass support profiles are summarized in Table 1 above and are given in Appendix 1
- Drawings: the cross-sections and detailed drawings of the elements are given in Appendix 1

3 DESCRIPTION OF THE TESTS

The object of the test is to verify the behaviour of the balustrade under:

- Static loads: horizontal outwardly directed static service and safety loads (linearly distributed and point horizontal loads). These loads must be combined with the wind loads (*Table 2* gives the dynamic peak pressure to be multiplied by a pressure coefficient of -2).
- Dynamic load: soft body impact test

The loads and their combinations for the static tests on the one hand and the drop height for the soft body impact test on the other hand, are described in the NBN B 03-004 "Balustrades of buildings" (2010). The requirements for residential buildings and offices were used.



After the static tests under horizontal loads, the element must meet the following criteria¹:

- Service:
 - Under load: glass deflection $\leq H/60$ or a maximum of 20 mm (25 mm²) where H is the protection height of the balustrade expressed in mm. The deformation is measured at the level of 1000 mm of the balustrade.
 - Residual deformation ≤ 3 mm
- Security: Residual deformation $\leq H/125$ (the glass may not break)

The observations after the tests were noted.

After the impact test, the following criteria must be met:

- The filling element may not separate from the structure of the balustrade
- No fragments that could injure persons may become detached. (In the case of balustrade in structural glass (e.g. clamped), it must continue to exercise its function under the application of a punctual load of 200 N for 30 seconds.)
- The impact body must not pass through the balustrade upon impact
- After the impact, the passage of the hexagonal calibre as defined in 5.2.1 of the NBN B03-004 may not be possible (under a negligible force) for the balustrades without panel
- After the impact, it must not be possible for the balustrades with filling panels to allow the passage of a steel ball with a diameter of 76 mm

Reference heights ze													
		Wind exposure class 1				Wind exposure class 2				Wind exposure class 3			
Reference speed	$v_b, 0$ (m/s)	26	25	24	23	26	25	24	23	26	25	24	23
Roughness categories		Reference heights (ze) to				Reference heights (ze) to				Reference heights (ze) to			
Coastal area	0												
Plain	I									2m	2m	4m	5m
Grove	II			2m	3m	3m	3m	4m	6m	5m	8m	8m	11m
Suburb - Forest	III	5m	6m	7m	9m	9m	12m	15m	19m	15m	19m	21m	21m
Town	IV	15m	17m	21m	25m	25m	30m	30m	30m	30m	30m	30m	30m
Dyn. peak pressure $q_p(z_e)$ =		544 Pa				693 Pa				815 Pa			
Reference heights ze													
		Wind exposure class 4				Wind exposure class 5				Wind exposure class 6			
Reference speed	$v_b, 0$ (m/s)	26	25	24	23	26	25	24	23	26	25	24	23
Roughness categories		Reference heights (ze) to				Reference heights (ze) to				Reference heights (ze) to			
Coastal area	0	3m				5m				8m			
Plain	I	4m	5m	8m	11m	7m	10m	14m	22m	12m	14m	27m	42m
Grove	II	8m	11m	15m	16m	14m	16m	16m	22m	16m	16m	27m	42m
Suburb - Forest	III	21m	21m	21m	21m	21m	21m	21m	22m	21m	21m	27m	42m
Town	IV	30m	30m	30m	30m	30m	30m	30m	30m	30m	30m	30m	42m
Dyn. peak pressure $q_p(z_e)$ =		950 Pa				1086 Pa				1224 Pa			
Reference heights ze													
		Wind exposure class 7											
Reference speed	$v_b, 0$ (m/s)	26	25	24	23								
Roughness categories		Reference heights (ze) to											
Coastal area	0	15m											
Plain	I	21m	31m	48m	78m								
Grove	II	21m	31m	48m	78m								
Suburb - Forest	III	21m	31m	48m	78m								
Town	IV	30m	31m	48m	78m								
Dyn. peak pressure $q_p(z_e)$ =		1364 Pa											

Table 2: Wind classes according to prNBN B 03-004 (in preparation)

¹ Between brackets and italics, the updated criteria according to the prNBN B03-004

² Absolute value. No more criteria in relation to the balustrade height.



4 RESULTS OF THE TESTS

The results that do not meet the test criteria are indicated in red and bold in the tables.

The results that meet the test criteria according to the standard under review are indicated in blue and bold in the tables.

4.1 PROFILE TYPE B (ALUMINCO)

4.1.1 STATIC TESTS

The results of the static tests are summarized in *Table 3*.

The static loads were applied to two glass panes. The tests were conducted with and without wind pressure.

Type B (Aluminco): residential buildings and offices						
Serviceability Limit States						
Profile model	Glazing type	Category	Base horizontal load for the load combination	Wind class (WCI)	Test criteria (mm)	
					Glass deformation (current standard 20 mm; pre-standard 25mm)	Residual deformation (3 mm)
Model B	1010.4 mix	A	$q_{k,h}$: 0,5 kN/m	/	3,94	1,64
		A	$Q_{kh,1}$: 0,5 kN	/	14,50	1,12
		B	$q_{k,h}$: 1,0 kN/m	/	9,89	0,46
		B	$Q_{kh,1}$: 1,0 kN	/	32,63	4,87
			$Q_{kh,2}$: 0,5 kN*		Not requested	
Model B	88.2 DG 41 float	A	$q_{k,h}$: 0,5 kN/m	/	7,40	0,6
		A	$Q_{kh,1}$: 0,5 kN	/	14,31	0,29
		A	$q_{k,h}$: 0,5 kN/m	1	10,27	0,22
		A	$Q_{kh,1}$: 0,5 kN	1	26,57	0,43
		A	$q_{k,h}$: 0,5 kN/m	2	13,26	0,09
		A	$Q_{kh,1}$: 0,5 kN	2	Not OK (see WCI 1)	OK (see WCI 1)
			$Q_{kh,2}$: 0,5 kN*		Not requested	
Ultimate Limit States						
Profile model	Glazing type	Category	Base horizontal load for the load combination	Wind class (WCI)	Test criteria (authorized max. deformation)	
					Residual deformation (9,6mm)	
Model B	1010.4 mix	A	$q_{k,h}$: 0,5 kN/m	/	0,76	
		A	$Q_{kh,1}$: 0,5 kN	/	2,78	
		B	$q_{k,h}$: 1,0 kN/m	/	Broken	
			$Q_{kh,2}$: 0,5 kN*		Not requested	
Model B	88.2 DG 41 float	A	$q_{k,h}$: 0,5 kN/m	/	1,08	
		A	$Q_{kh,1}$: 0,5 kN	/	0,92	
		A	$q_{k,h}$: 0,5 kN/m	1	2,66	
		A	$Q_{kh,1}$: 0,5 kN	1	0,78	
		A	$q_{k,h}$: 0,5 kN/m	2	0,76	
		A	$Q_{kh,1}$: 0,5 kN	2	0,80	
	$Q_{kh,2}$: 0,5 kN*		Not requested			

Table 3: Results of the static tests

Note: The values in red do not satisfy and the values in blue satisfy according to the prNBN B03-004, but not according to the current NBN B03-004

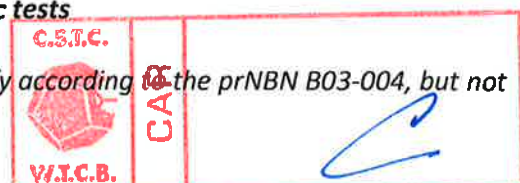

- with $q_{k,h}$: uniform horizontal linear load applied at the level of 1000 mm of the railing³
 $Q_{kh,1}$: horizontal point load for the local verification at the 1000 mm of the railing³
 $Q_{kh,2}$: horizontal point load for the location verification under protection height, applied to the most unfavourable position
 *: These tests were not carried out as the uppermost boundary conditions are more decisive

Conclusion

The tested balustrade (Aluminco profile type B, with an 1010.4 mix) meets the requirements of **NBN B03-004** for *residential buildings and offices* w.r.t. the uniform horizontal linear static loads

- in Serviceability Limit States
- without wind load

The tested balustrade (Aluminco profile type B, with an 1010.4 mix) meets the requirements of **NBN B03-004** for *residential buildings* w.r.t. the concentrated static loads

- in Serviceability Limit States
- without wind load

The tested balustrade (Aluminco profile type B, with an 1010.4 mix) meets the requirements of **NBN B03-004** for *residential buildings* w.r.t. the uniform horizontal linear and concentrated static loads

- in Ultimate Limit States
- without wind load

The tested balustrade (Aluminco profile type B, with an 88.2 DG 41) meets the requirements of **NBN B03-004** for *residential buildings* w.r.t. the uniform horizontal linear static loads

- in Serviceability Limit States and Ultimate Limit States
- with wind class 2

The tested balustrade (Aluminco profile type B, with an 88.2 DG 41) meets the requirements of **NBN B03-004** for *residential buildings* w.r.t. the concentrated static loads

- in Serviceability Limit States
- without wind load

The tested balustrade (Aluminco profile type B, with an 88.2 DG 41) meets the requirements of **NBN B03-004** for *residential buildings* w.r.t. the concentrated static loads

- in Ultimate Limit States
- with wind class 2

4.1.2 DYNAMIC TESTS

The results of the impact test out are summarized in

Balustrade	Drop height (mm)	Impact point	Comments
Model B with 1010.4 mix	300	110cm from the ground, in the corner of the glass panel	OK, meets the criteria presented in § 3
	450	110cm from the ground, in the corner of the glass panel	OK, meets the criteria presented in § 3
Model 6011 with 88.2 DG 41 float	300	110cm from the ground, in the corner of the glass panel	OK, meets the criteria presented in § 3

Table 4.

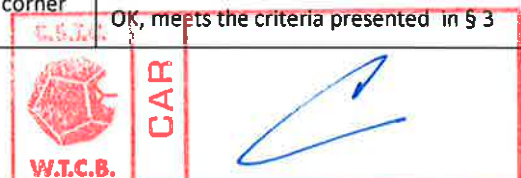

³From the uppermost level of the profile foot

Balustrade	Drop height (mm)	Impact point	Comments
Model B with 1010.4 mix	300	110cm from the ground, in the corner of the glass panel	OK, meets the criteria presented in § 3
	450	110cm from the ground, in the corner of the glass panel	OK, meets the criteria presented in § 3
Model 6011 with 88.2 DG 41 float	300	110cm from the ground, in the corner of the glass panel	OK, meets the criteria presented in § 3

Table 4: Results of the soft body impact test

Conclusion

The tested balustrade (Aluminco profile type B, with an 1010.4 mix) meets the requirements of **NBN B03-004** for residential and office buildings w.r.t. the impact test of a soft heavy body.

The tested balustrade (Aluminco profile type B, with an 88.2 DG 41) meets the requirements of **NBN B03-004** for residential buildings w.r.t. the impact test of a soft heavy body.

4.2 PROFILE TYPE E (ALUMINCO)

4.2.1 STATIC TESTS

The results of the static tests are summarized in *Table* .

The static loads were applied to two glass panes. The tests were conducted with and without wind pressure.

Type E (Aluminco): residential buildings and offices						
Serviceability Limit States						
Profile Model	Glazing type	Category	Base horizontal load for the load combination	Wind class (WCI)	Test criteria (mm)	
					Glass deformation (current standard 20 mm; pre-standard 25mm)	Residual deformation (3 mm)
Model E	1010.2 DG 41	B	$q_{k,h}: 1,0 \text{ kN/m}$	/	9,80	0,65
		B	$Q_{kh,1}: 1,0 \text{ kN}$	/	18,47	0,15
		A	$q_{k,h}: 0,5 \text{ kN/m}$	2	8,15	1,24
		A	$Q_{kh,1}: 0,5 \text{ kN}$	2	OK (see cat. B)	OK (see cat. B)
		A	$q_{k,h}: 0,5 \text{ kN/m}$	4	11,52	0,79
			$Q_{kh,2}: 0,5 \text{ kN}^*$		Not requested	
Model E	1010.4 mix	A	$q_{k,h}: 0,5 \text{ kN/m}$	1	8,18	0,63
		A	$q_{k,h}: 0,5 \text{ kN/m}$	2	9,72	0,27
		A	$q_{k,h}: 0,5 \text{ kN/m}$	3	11,44	0,30
			$Q_{kh,2}: 0,5 \text{ kN}^*$		Not requested	
Ultimate Limit States						
Profile Model	Glazing type	Category	Base horizontal load for the load combination	Wind class (WCI)	Test criteria (authorized max. deformation)	
					Residual deformation (9,6mm)	
Model E	1010.2 DG 41	B	$q_{k,h}: 1,0 \text{ kN/m}$	/	3,30	
		B	$Q_{kh,1}: 1,0 \text{ kN}$	/	0,73	
		A	$q_{k,h}: 0,5 \text{ kN/m}$	2	3,00	
		A	$q_{k,h}: 0,5 \text{ kN/m}$	4	1,00	
			$Q_{kh,2}: 0,5 \text{ kN}^*$		Not requested	
Model E	1010.4 mix	A	$q_{k,h}: 0,5 \text{ kN/m}$	1	1,73	

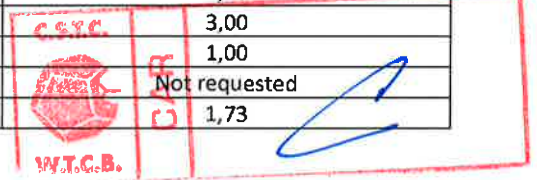

	A	$Q_{kh,1}$: 0,5 kN	1	2,13
	A	$q_{k,h}$: 0,5 kN/m	2	1,20
	A	$Q_{kh,1}$: 0,5 kN	2	2,02
	A	$q_{k,h}$: 0,5 kN/m	3	1,05
	A	$Q_{kh,1}$: 0,5 kN	3	Broken
		$Q_{kh,2}$: 0,5 kN*		Not requested

Table 5: Results of the static tests

Note: The values in red do not satisfy and the values in blue satisfy according to the prNBN B03-004, but not according to the current NBN B03-004

- with $q_{k,h}$: uniform horizontal linear load applied at the level of 1000 mm of the railing⁴
 $Q_{kh,1}$: horizontal point load for the local verification at the 1000 mm of the railing³
 $Q_{kh,2}$: horizontal point load for the location verification under protection height, applied to the most unfavourable position
 *: These tests were not carried out as the uppermost boundary conditions are more decisive

Conclusion

The tested balustrade (Aluminco profile type E, with an 1010.2 DG 41) meets the requirements of **NBN B03-004** for *residential buildings* w.r.t. the uniform horizontal linear and concentrated static loads

- in Serviceability Limit States and Ultimate Limit States
- with wind class 4

The tested balustrade (Aluminco profile type E, with an 1010.2 DG 41) meets the requirements of **NBN B03-004** for *office buildings* w.r.t. the uniform horizontal linear and concentrated static loads

- in Serviceability Limit States and Ultimate Limit States
- without wind

The tested balustrade (Aluminco profile type E, with an 1010.4 mix) meets the requirements of **NBN B03-004** for *residential buildings* w.r.t. the uniform horizontal linear static loads



- in Serviceability Limit States and Ultimate Limit States
- with wind class 3

The tested balustrade (Aluminco profile type E, with an 1010.4 mix) meets the requirements of **NBN B03-004** for *residential buildings* w.r.t. the concentrated static loads

- in Ultimate Limit States
- with wind class 2

4.2.2 DYNAMIC TESTS

The results of the impact test are summarized in

Balustrade	Drop height (mm)	Impact point	Comments
			 

⁴From the uppermost level of the profile foot

Model E with 1010.2 DG 41	450	110cm from the ground, in the corner of the glass panel	OK, meets the criteria presented in § 3
---------------------------	-----	---	---

Table 6.

Balustrade	Drop height (mm)	Impact point	Comments
Model E with 1010.2 DG 41	450	110cm from the ground, in the corner of the glass panel	OK, meets the criteria presented in § 3

Table 6: Results of the soft body impact test

Conclusion

The tested balustrade (Aluminco profile type E, with an 1010.2 DG 41) meets the requirements of **NBN B03-004** for residential and office buildings w.r.t. the impact test of a soft heavy body.

5 CONCLUSION

The following table provides an overview of the balustrades that meet the requirements of NBN B 03-004 for specific use with respect to the uniform horizontal linear and concentrated static loads and the impact test of a soft heavy body.

Profile types	Glazing types	Static tests (horizontal loads)				Impact test
		Usage boundary conditions		Uppermost boundary conditions		
		Uniform linear	Concentrated	Uniform linear	Concentrated	
Model B	1010.4 mix float	Residential and office buildings, without wind load	Residential buildings, without wind load	Residential buildings, without wind load		Residential and office buildings
Model B	88.2 DG 41 float	Residential buildings, wind class 2	Residential buildings, without wind load	Residential buildings, wind class 2		Residential buildings
Model E	1010.2 DG 41 float	Residential buildings, wind class 4 Office buildings, without wind load	Residential buildings, wind class 2 Office buildings, without wind load	Residential buildings, wind class 4 Office buildings, without wind load	Office buildings, without wind load	Residential and office buildings
Model E	1010.4 mix float	Residential buildings, wind class 3	/	Residential buildings, wind class 3	Residential buildings, wind class 2	/

By comparison and **for the same type of profiles**, one can expect that a toughened glass would have **at least the same performance** as a float glass of the same composition and dimensions.

6 LIST OF APPENDIXES

Appendix 1: Detail drawings of the various profiles



Appendix 1: Detail drawings of the various profiles

Crystal line Type B

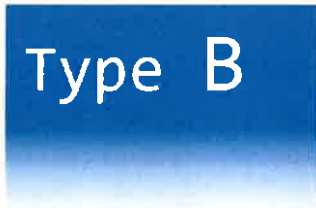

Glas ondersteund systeem in opbouw
Système de base apparente supportant le vitrage
 (pose à la française)

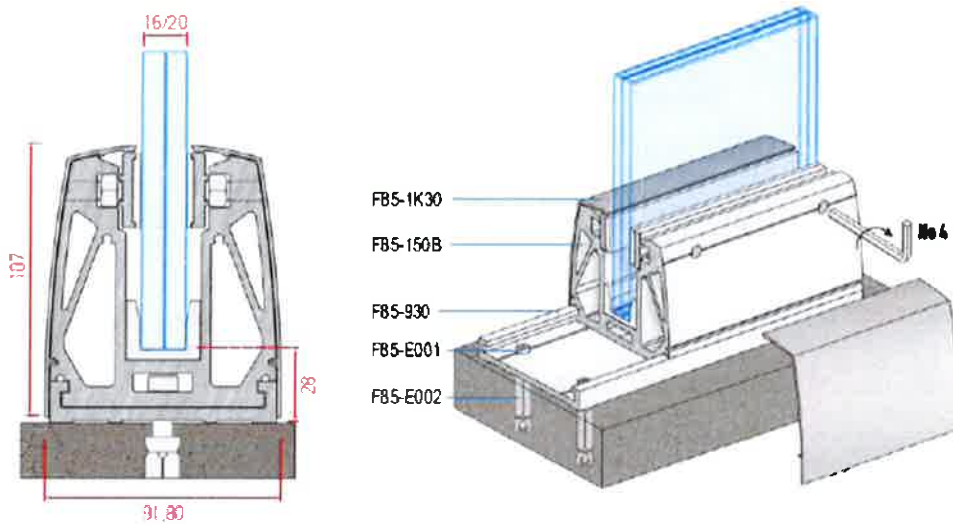

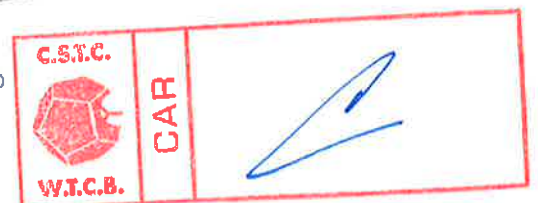
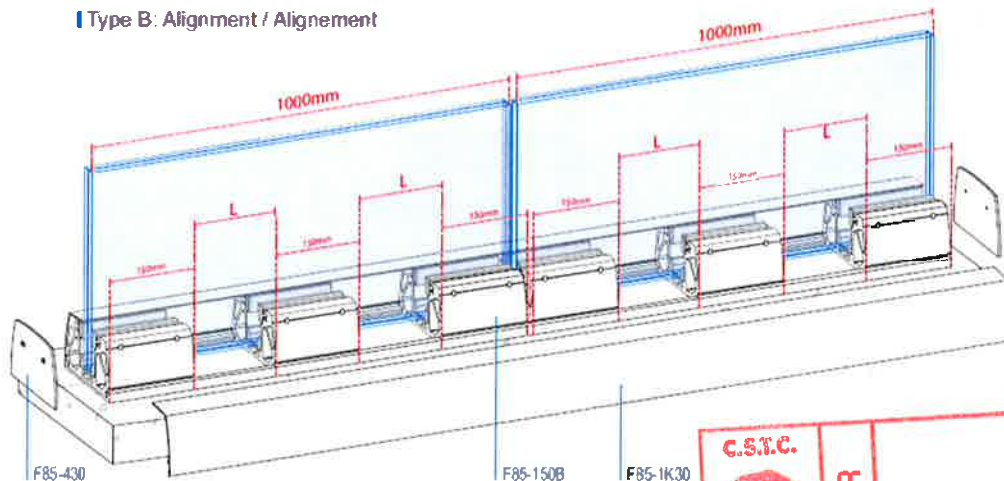

Type B: Alignment / Aligement

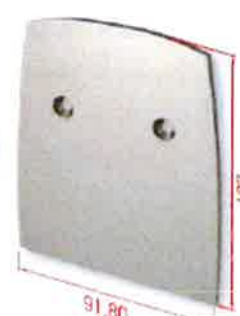

Crystal line Type B (cont'd)

Profiles & Accessories / Profils & Accessoires

			
100,30 35,50	88,10 16,30	91,80 107	16/20 91,80 107
Base cover Cache de la base	Base guide Rail de la base	Cap Capuchon	Cap Capuchon
Code F85-1K30	Code F85-930	Code F85-430	Code F85-430L (16mm) F85-430M (20mm)
Weight / Poids 545 gr/m	Weight / Poids 1565 gr/m	Package Emballage 20 pcs	Package Emballage 20 pcs.
Length / Longueur 6 m	Length / Longueur 6 m		

Glass supporting base / Base supportant le vitrage

Bases include screws, gaskets and pressure plates.
 Les bases incluent des vis, des joints et des plaquettes de pression.

 For glass 16mm*
 Pour vitrage 16mm*

Code F85-150B/16
Package Emballage 12 pcs.

 For glass 20mm
 Pour vitrage 20mm

Code F85-150B/20
Package Emballage 12 pcs.

* in case of using a 16mm glass,
 cover gasket is compulsory
 En cas de fixation d'un vitrage
 de 16mm, le joint des caches est
 indispensable



Cover gasket Joint des caches
Code F85-434
Length Longueur 250 m



Crystal line Type C

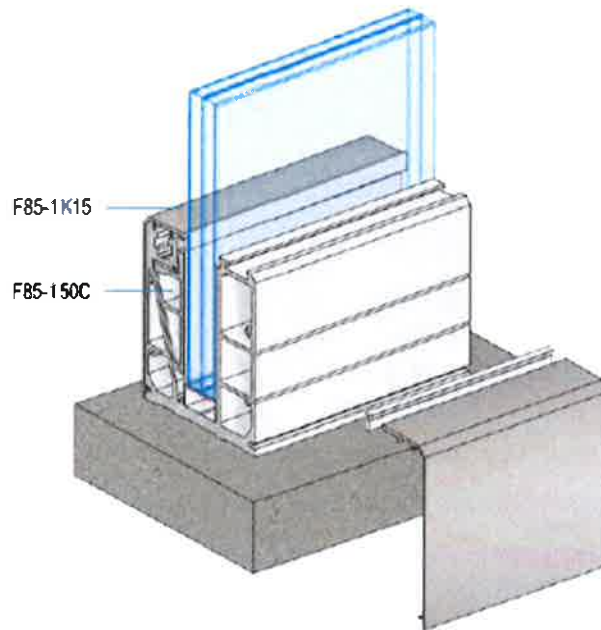
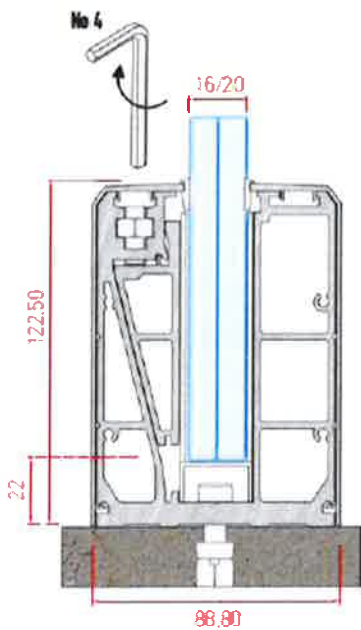

Type C

Glas ondersteund systeem in opbouw
Système de base apparente supportant le vitrage
 (pose à la française)

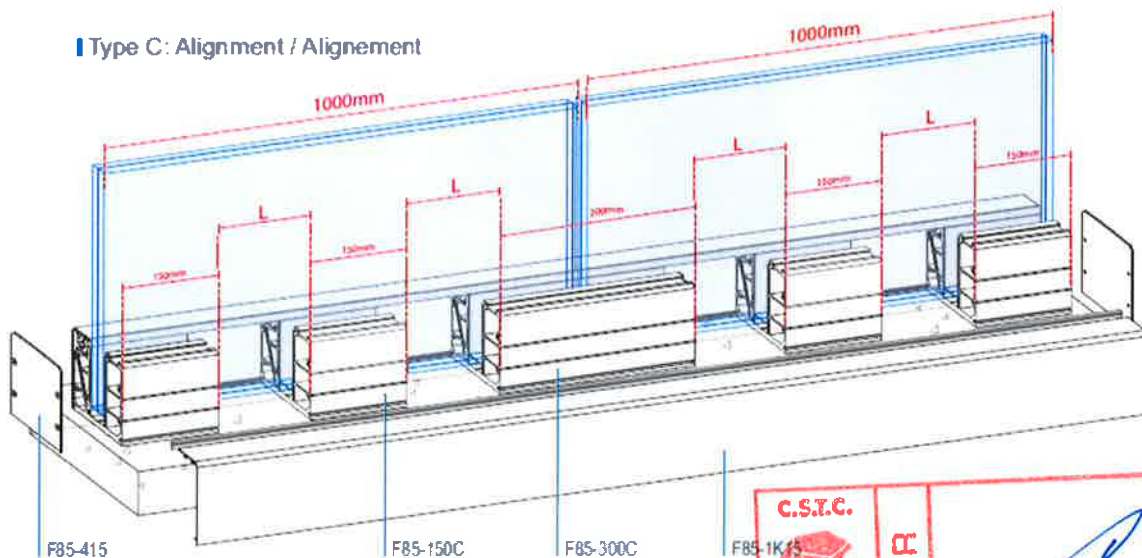

Type C: Alignment / Aligement



 C.S.T.C. W.T.C.B.	CAR	
--	------------	---

Crystal line Type C (cont'd)

Profiles & Accessories / Profils & Accessoires

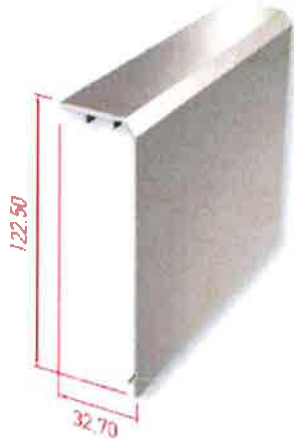
 Base cover
 Cache de la base

Code	F85-1K15
Weight / Poids	696 gr/m
Length / Longueur	6 m

 Cap
 Capuchon

Code	F85-415
Package Emballage	20 pcs.

 Cap
 Capuchon

Code	F85-415L (16mm) F85-415M (20mm)
Package Emballage	20 pcs.

Glass supporting base / Base supportant le vitrage

Bases include screws and gaskets. Type C bases are used in both in-floor and on-floor systems.

Les bases incluent des vis et joints. Les bases de Type C sont utilisées en apparent aussi bien qu'en encastré.



 Code
F85-150C/16*
F85-150C/20**

Package Emballage	12 pcs
----------------------	--------

 Code
F85-300C/16*
F85-300C/20**

Package Emballage	6 pcs.
----------------------	--------

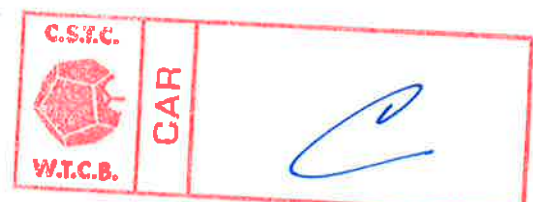
* For glass 16mm / Pour vitrage 16mm
 ** For glass 20mm / Pour vitrage 20mm



Crystal line Type E

Type E

Glas ondersteund systeem in opbouw
Système de base apparente supportant le vitrage
(pose à la française)

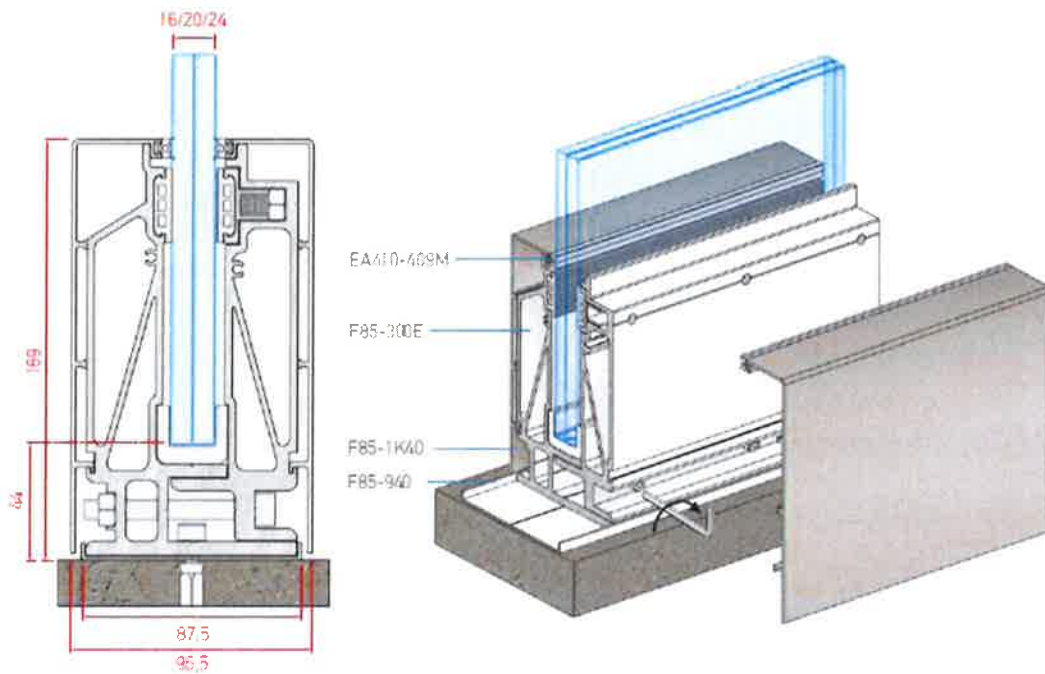

Type E Alignment

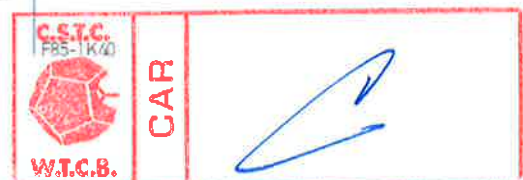
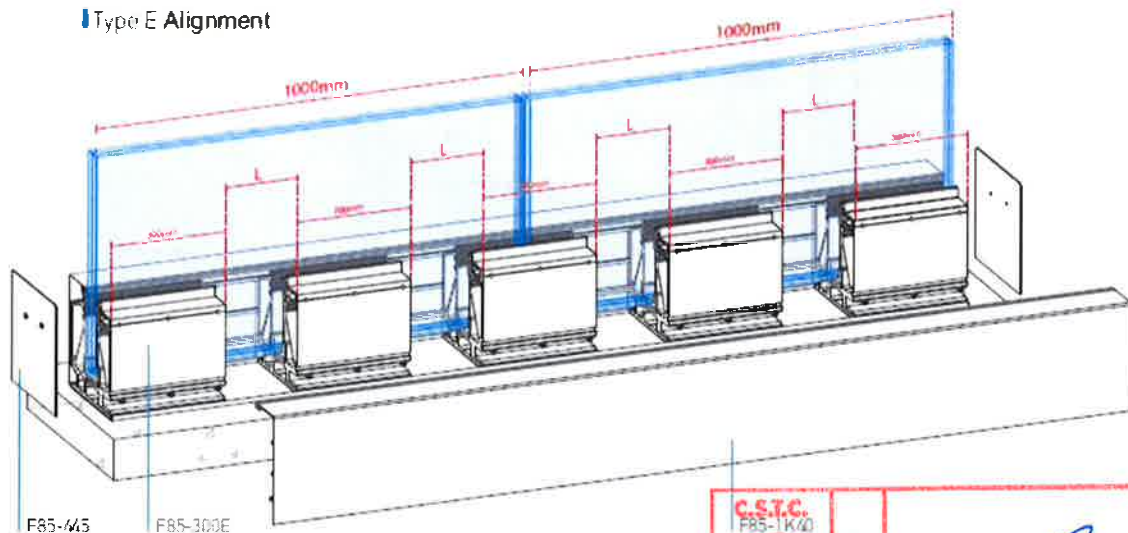

Crystal line Type E (cont'd)

Profiles & Accessories

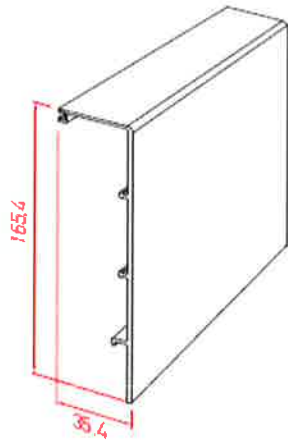

Base Cover

Code **F85-1K40**

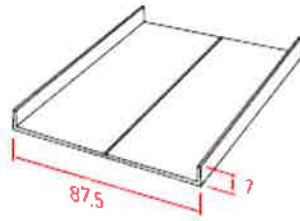

Base Rail

Code **F85-940**



Cover

Code **F85-445/16** (16mm)
F85-445/20 (20mm)
F85-445/24 (24mm)



Glass Gasket

Code **EA410-409M**

Glass supporting base

Bases include screws, gaskets and pressure plates.

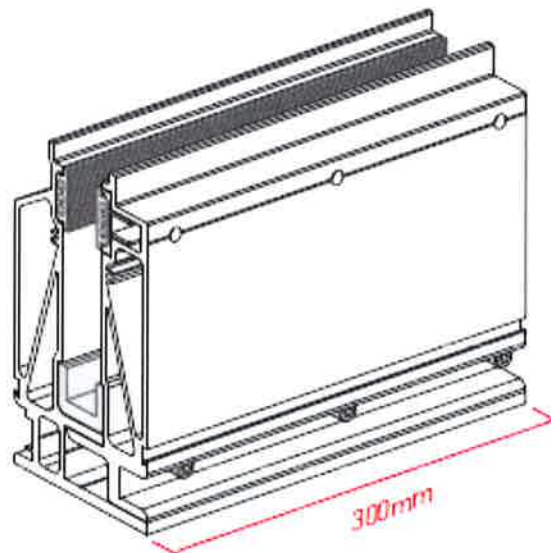

Code **F85-300E/16** (16mm*) *For glass 16mm
F85-300E/20 (20mm**) ** For glass 20mm
F85-300E/24 (24mm***) ***For glass 24mm

